

2

1

B

B

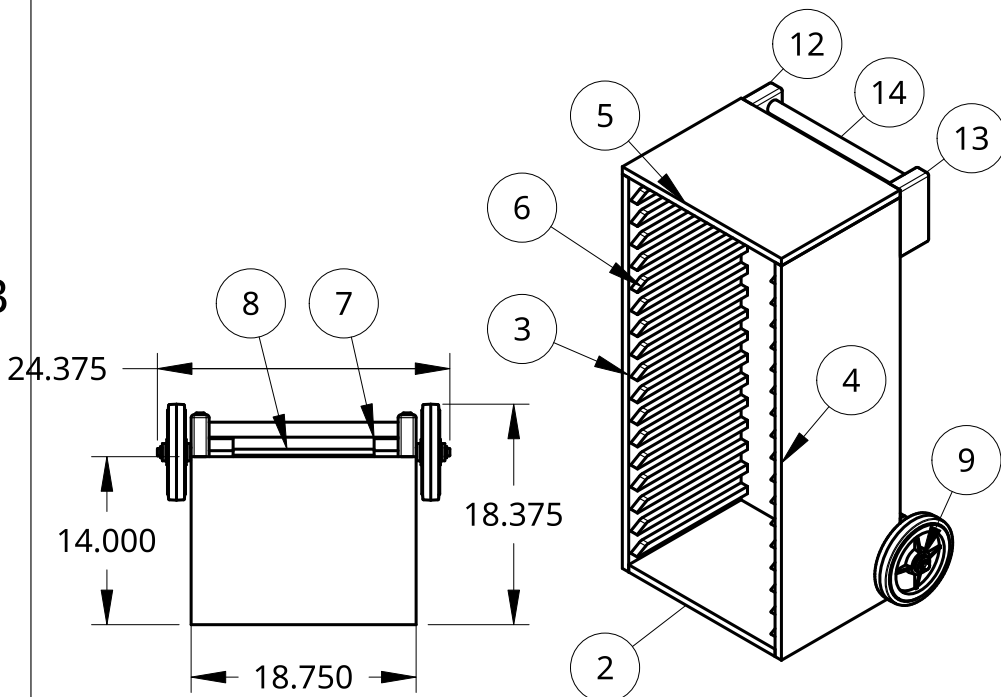

Item	Quantity	Name
1	1	Back
2	1	Bottom
3	1	Left
4	1	Right
5	1	Top
6	34	Slider
7	2	Axle Holder
8	1	Axle
9	2	Slip Bearing
10	2	8" Colson Wheel
11	2	Push-On Retaining Cap
12	1	Handle Holder Right
13	1	Handle Holder Left
14	1	Handle
15	6	Bumpon Foot

A

A

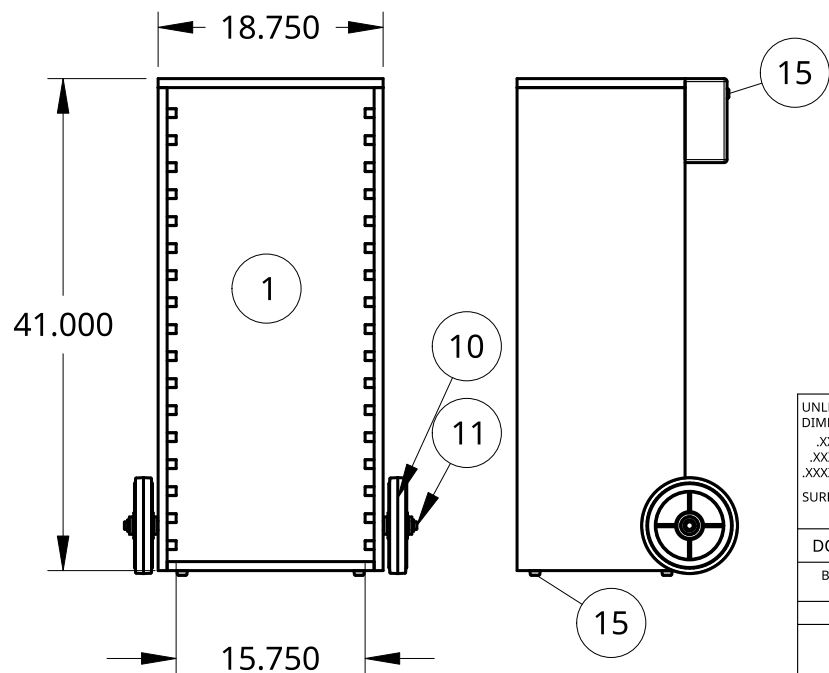
UNLESS OTHERWISE SPECIFIED,
DIMENSIONS ARE IN INCHES

.XX = ±.0-	ANGULAR = ± °
.XXX = ±.00-	FRACTIONAL = ±
.XXXX = ±.000-	

SURFACE FINISH

DO NOT SCALE DRAWING

BREAK ALL SHARP EDGES AND
REMOVE BURRS

THIRD ANGLE PROJECTION



	NAME	DATE
DRAWN	BLAKE BOURQUE	12/31/2020
CHECKED		
APPROVED		
MATERIAL	FINISH	

TITLE			
PART BIN ORGANIZER RACK			
SIZE	DWG NO.	REV.	
A		Overview	
SCALE	WEIGHT	SHEET	1 of 4
1:16			

2

1

2

1

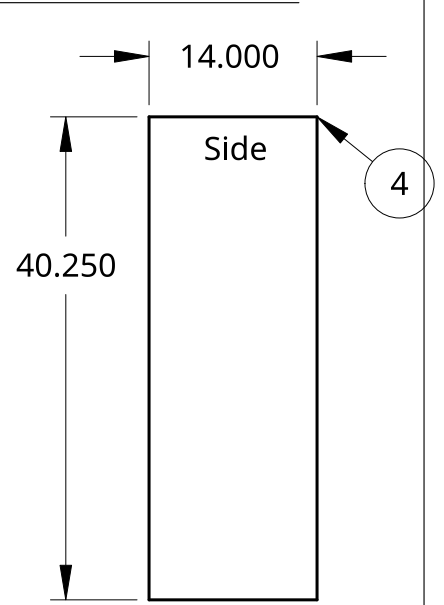
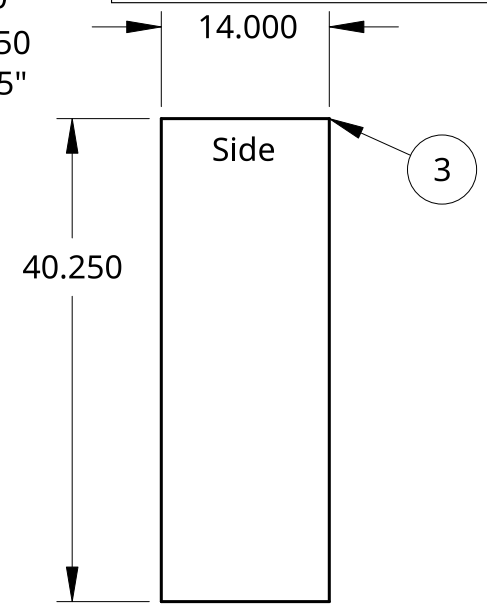
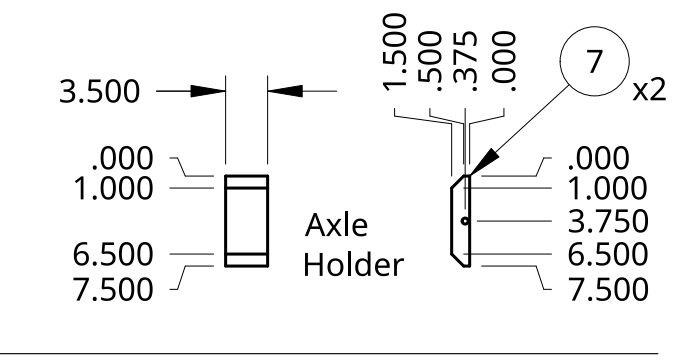
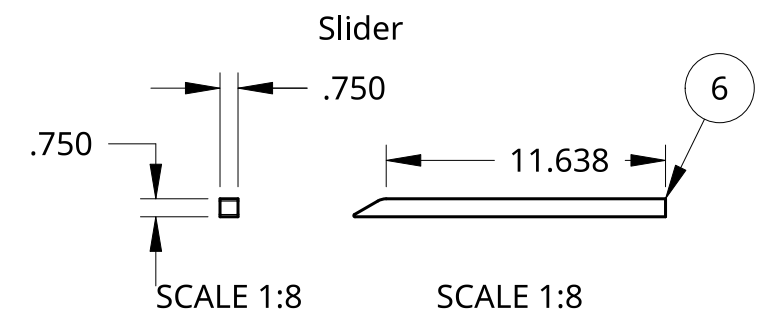
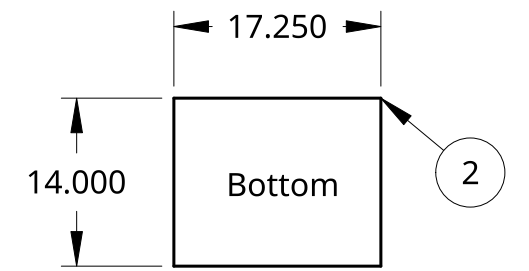
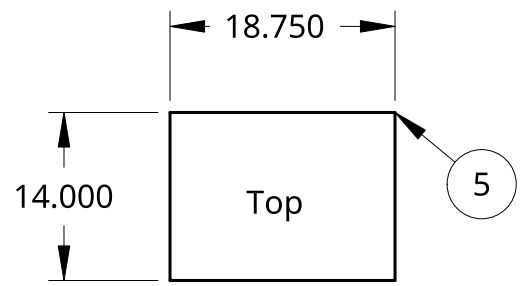
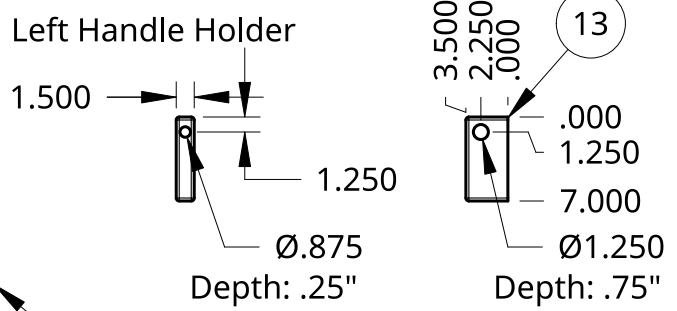
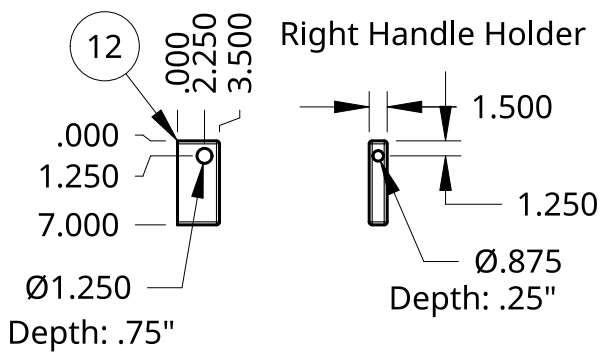
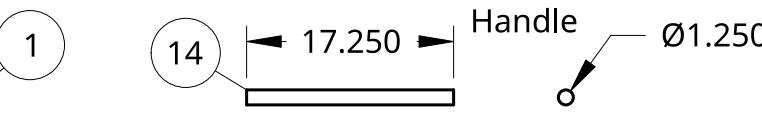
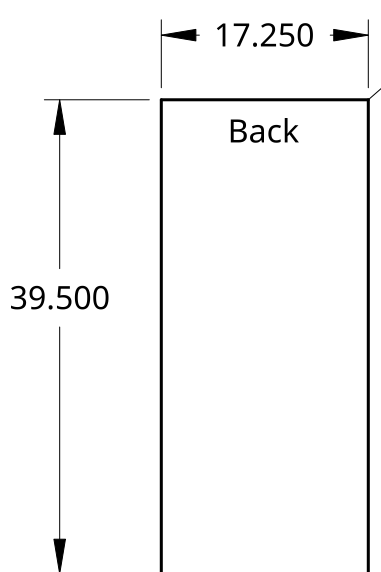

DWG NO.	Parts	SIZE	A	SCALE	1:16	SHEET	2 of 4	REV.
---------	-------	------	---	-------	------	-------	--------	------

2

1

2

1

B

B

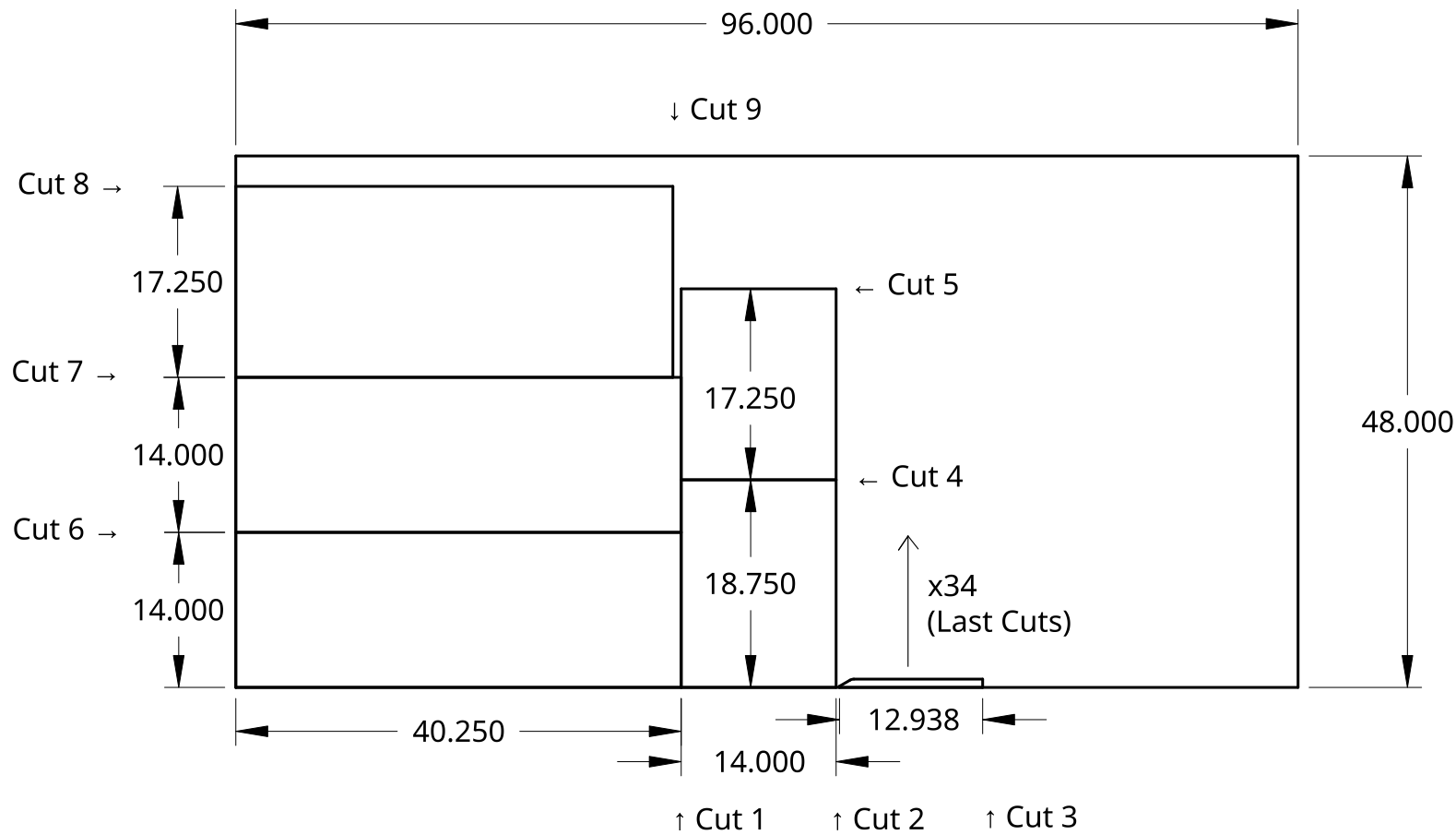

A

A

2

1

DWG. NO.	Cut Sheet	SIZE	A	SCALE	1:16	SHEET	3 of 4	REV.
----------	-----------	------	---	-------	------	-------	--------	------

2

1

B

B

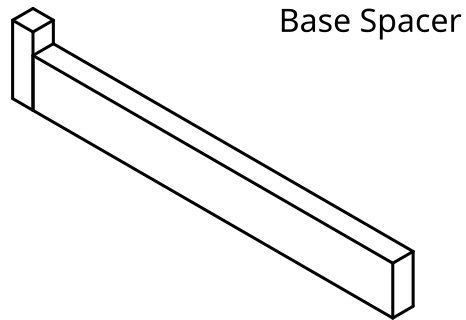

Base Spacer

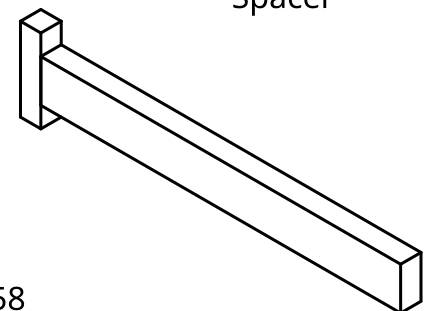

Spacer

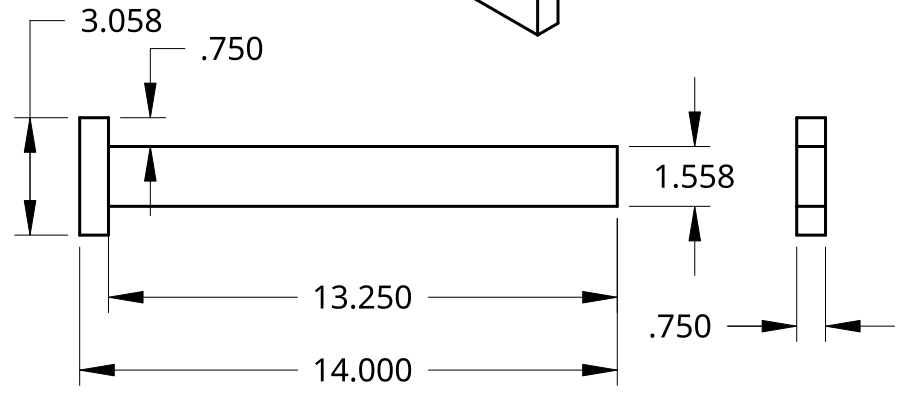
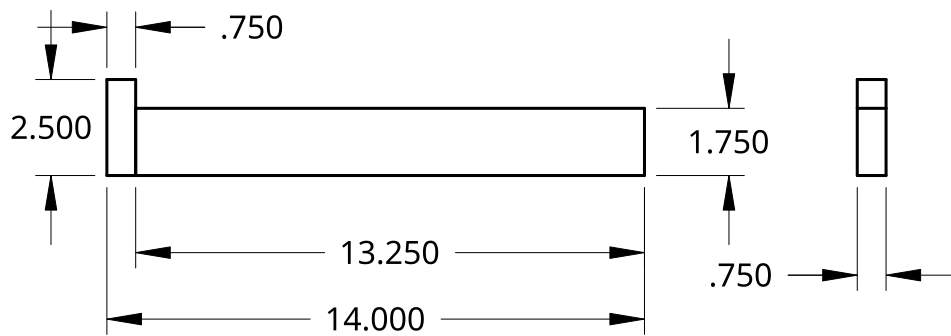

A

A

2

1

DWG NO.	Spacers	SIZE	A	SCALE	1:5	SHEET	4 of 4	REV.
---------	---------	------	---	-------	-----	-------	--------	------